

Bảng thông số sản phẩm

Thông số kỹ thuật



Monolithic tower lights, Harmony XVG, 60mm, red orange green blue, steady light, aluminium tube mounting and fixing plate, IP53, 24V AC/DC

XVGB4H

Main

Range of product	Harmony XVG
product or component type	Complete pre-wired monolithic tower light
Beacon or indicator bank unit type	4 illuminated units
Material	PC (UL94 V-2): globe ABS (UL94HB): tube body Aluminium: tube
Mounting diameter	60 mm
Component name	XVG
device mounting	Tube mounting with fixing plate
Light source	LED steady red LED steady green LED steady amber LED steady blue
Light block color	Red/orange/green/blue
Indicator bank base type	Base without buzzer

Complementary

rated supply voltage	24 V AC/DC
cable cross section	0.33 mm ²
Discrete output type	PNP and NPN
[Uimp] rated impulse withstand voltage	0.5 kV
Current consumption	135 mA
power consumption in W	3.3 W
Fundamental frequency	2.64 kHz
net weight	0.4 kg

Environment

Product certifications	CE EAC
Ambient air temperature for storage	-35...70 °C
Ambient air temperature for operation	-10...50 °C
IP degree of protection	IP53

Packing Units

Unit Type of Package 1	PCE
Number of Units in Package 1	1
Package 1 Height	8.500 cm
Package 1 Width	14.000 cm
Package 1 Length	56.500 cm
Package 1 Weight	611.000 g
Unit Type of Package 2	S04
Number of Units in Package 2	6
Package 2 Height	30.000 cm
Package 2 Width	40.000 cm
Package 2 Length	60.000 cm
Package 2 Weight	4.316 kg
Unit Type of Package 3	P06
Number of Units in Package 3	24
Package 3 Height	75.000 cm
Package 3 Width	80.000 cm
Package 3 Length	60.000 cm
Package 3 Weight	25.264 kg

Contractual warranty

Warranty	18 months
----------	-----------

Bền vững

Nhãn **Green Premium™** là cam kết của Schneider Electric trong việc cung cấp sản phẩm với hiệu suất môi trường tốt nhất. Green Premium cam kết tuân thủ các quy định mới nhất, minh bạch về tác động môi trường, cũng như các sản phẩm tuần hoàn và CO₂ thấp.

Hướng dẫn đánh giá tính bền vững của sản phẩm là tài liệu kỹ thuật phổ thông giúp làm rõ các tiêu chuẩn nhãn sinh thái toàn cầu và cách diễn giải việc khai báo môi trường.

[Tìm hiểu thêm về Green Premium >](#)

[Hướng dẫn đánh giá về sự bền vững của sản phẩm >](#)



Minh bạch [RoHS/REACH](#)

Hiệu suất sức khỏe

 Mercury Free

 RoHS Exemption Information [Yes](#)

Chứng nhận & Tiêu chuẩn

Reach Regulation [REACH Declaration](#)

Eu RoHS Directive Pro-active compliance (Product out of EU RoHS legal scope)

China RoHS Regulation [China RoHS declaration](#)

Environmental Disclosure [Product Environmental Profile](#)

Circularity Profile [End of Life Information](#)

Dimensions

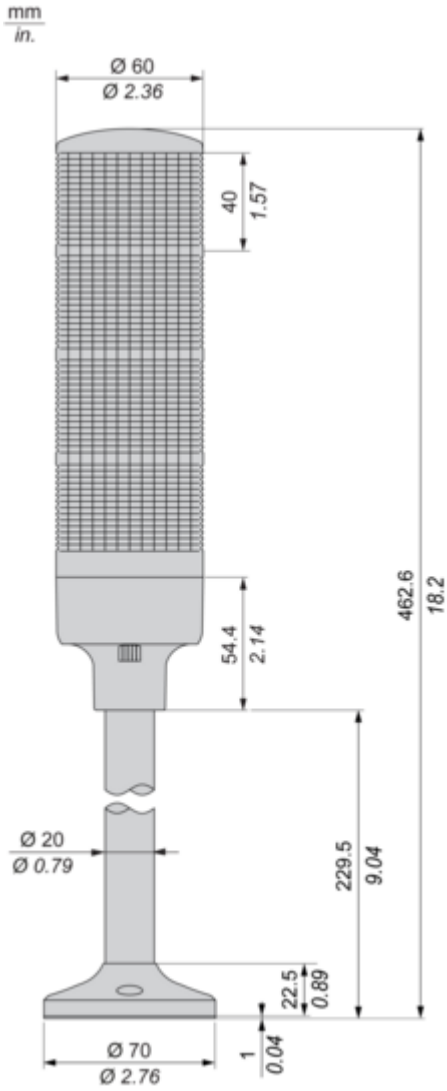

Mounting and Clearance

Mounting

Ø54 mm/2.13 in., Standard

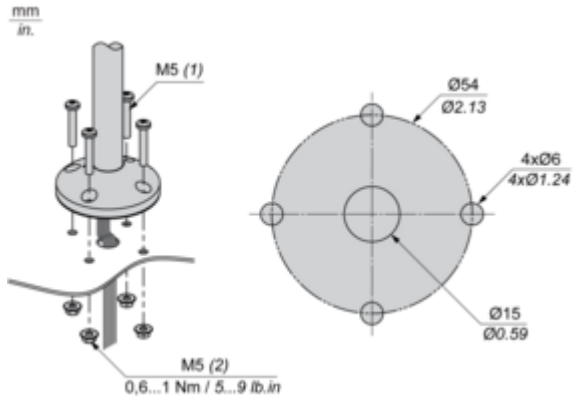

(1) Thickness + 10 mm/0.39 in.

(2) Hexagon Nut with flange

Connections and Schema

Wiring

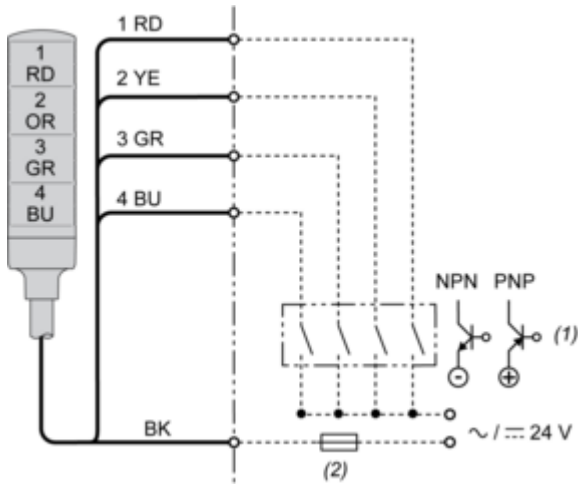

(1) "ON" for lighting and/or applying continuous sound.

(2) Fuse (rated current: 0.5 A)

RD : Red

YE : Yellow

GR : Green

BU : Blue

OR : Orange

BK : Black